

# PERSPECTIVES

OPINION

## The neuro-symphony of stress

Marian Joëls and Tallie Z. Baram

**Abstract** | The impact of stress on brain function is increasingly recognized. Various substances are released in response to stress and can influence distinct neuronal circuits, but the functional advantages of having such a diversity of stress mediators remain unclear. Individual neurotransmitter, neuropeptide and steroid stress mediators have specific spatial and temporal niches, but these niches also overlap. In addition, the effects of individual mediators on neuronal function and plasticity are integrated, and emerging evidence suggests that there is crosstalk between them. Together, this results in the stress instruments producing an orchestrated ‘symphony’ that enables fine-tuned responses to diverse challenges.

Any actual or potential disturbance of an individual’s environment — a ‘stressor’ — is recognized or perceived by specific brain regions. The subjective state of sensing potentially adverse changes in the environment is called ‘stress’ and leads to the release of molecules that we here call ‘stress mediators’, which bind to receptor targets. Each of these mediators acts on specific neuronal populations, resulting in unique downstream effects. Together, these effects constitute the ‘stress response’, which enables the animal to adapt to the changing environment<sup>1–4</sup>.

A perplexing aspect of the stress response is its complexity. Various stress mediators have been described, including neurotransmitters (for example, noradrenaline and serotonin), peptides (for example, corticotropin-releasing hormone (CRH), other members of the CRH family and vasopressin) and steroid hormones (for example, cortisol in humans and corticosterone in rodents). What is the reason for the existence of these multiple instruments? Is there not a staggering degree of redundancy?

In this Perspective we initially discuss the characteristic spatial and temporal niches of key stress mediators and provide emerging evidence that these niches overlap, affording opportunities for interactions between mediators. We then highlight these interactions, showing that the stress mediators act in concert. We argue that the diversity of the instruments of stress, rather than being redundant,

enables both optimal niches of action for each mediator and interactions between the multiple mediators that orchestrate our brain’s remarkable ability to respond — and adapt — to a dynamic environment.

### A need for multiple mediators

Stress signifies a potential or actual threat that requires immediate changes in behaviour as well as a modification of future behaviours. This is achieved through the modulation of neuronal functioning at several levels of the

CNS — levels that govern decision making, learning and memory as well as hormonal, autonomic and emotional responses.

Different types of stressors require different responses (FIG. 1). The stressor type influences the repertoire of neuronal populations that perceive a potential threat, as well as the neurons and stress mediators that are engaged in the adaptive response. For example, physical stressors such as blood loss, trauma and cold rapidly recruit the brainstem and hypothalamic regions<sup>1,3</sup>, whereas psychological stressors such as social embarrassment, examinations or deadlines primarily engage stress mediators in brain regions that subserve emotion (the amygdala and the prefrontal cortex), learning and memory (the hippocampus) and decision making (the prefrontal cortex)<sup>2,4,5</sup>. These are not segregated systems, because physical stressors often have psychological aspects and vice versa.

The duration of the stressor also greatly influences the nature of the neuronal responses (FIG. 1). Acute stressors — for example, a rapidly approaching car — cause a rapid surge of neurotransmission, neuronal activation and hormone release. This is followed by rapid return to baseline levels, although the temporary activation of, for example, hippocampal and hypothalamic neurons can ultimately lead to alterations

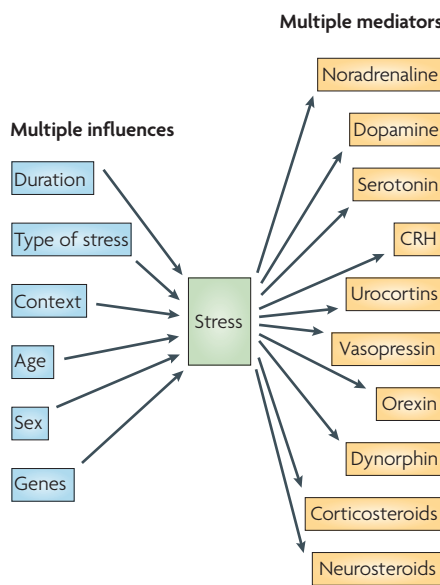

**Figure 1 | Different stressors require different responses.** Many factors influence the pattern and magnitude of the response to stress, including the duration of stress exposure (acute versus chronic), the type of stress (physical versus psychological), the stress context (for example, time of day), the developmental stage of the animal (newborn, adult or aged) and the animal’s sex and genetic background. The panoply of unique stress situations and neuronal populations that respond to them to affect neural and behavioural plasticity on a timescale from seconds to years is not well served by a single mediator — hence the need for multiple instruments, so that each combination of mediators addresses the specific aspects of a stressor. The molecules that convey the stress signal to the CNS and that contribute to the resulting functional changes in the CNS (stress mediators) include monoamines, neuropeptides and steroid hormones, examples of which are shown on the right. Each mediator has a preferred activity domain in space and time.

Table 1 | **Examples of stress-activated neuropeptides in the brain**

Peptide	Release location	Receptor (and receptor location)	Functions related to stress
CRH	Central amygdala <sup>30,34,35</sup>	CRHR1 (basolateral amygdala) <sup>30,34,38,78</sup> CRHR2 (REF. 74)	Stress/emotional memory, anxiety <sup>30,33,35,80</sup> Termination of stress-related anxiety <sup>31–33</sup>
	Locus coeruleus <sup>28</sup>	CRHR1 (locus coeruleus) <sup>60,78</sup>	Interaction with noradrenaline systems <sup>28</sup>
	Hippocampal interneurons <sup>27,56</sup>	CRHR1 (pyramidal cells) <sup>11,39,48,56,78</sup>	Stress-related learning and memory <sup>3,36,39</sup>
	BnST <sup>26,81</sup>	CRHR1 (REFS 48,81) (nucleus accumbens) <sup>81</sup> and CRHR2 (REFS 74,78,81)	Stress-related anxiety <sup>26,30</sup>
Urocortin	Non-ganglionic Edinger–Westphal nucleus <sup>41</sup>	CRHR1 and CRHR2	Interaction with CRH systems during acute and chronic stress
Urocortin 2 and 3		CRHR2 (REF. 41)	Role in stress not established
Vasopressin	Hypothalamic dendrites BnST and amygdala <sup>25,26,43</sup>	V1A (septum, hippocampus, BnST and other areas) and V1B	Stress-related and social memory, and perhaps emotionality <sup>25,26,43</sup>
Orexin	Lateral hypothalamic area <sup>26</sup>	OX1 and OX2	Stress-related energy and sleep homeostasis
Dynorphin	Hippocampal dendrites <sup>82</sup>	Several opioid receptors <sup>26</sup>	Stress-related dysphoria <sup>26</sup>

BnST, bed nucleus of the stria terminalis; CRH, corticotropin-releasing hormone; CRHR, CRH receptor; OX, orexin receptor; V1, vasopressin receptor 1.

in gene expression, which in turn change subsequent neuronal responses. By contrast, chronic stress (typically defined as stress that lasts a week or more) provokes sustained and/or progressive changes in the expression of particular genes, structural alterations in neurons and changes in neuronal firing patterns throughout the brain<sup>4,6</sup>. If such changes persist they can result in prolonged deviations from the original functioning of the network<sup>3</sup>.

In addition, the characteristics of the responding brain determine the pattern and magnitude of its response to a stressor. For example, the age of the animal influences the likelihood of a signal being perceived as a stressor. It also influences the mediators that are released by stressors, and their consequences<sup>3,7,8</sup>. For example, in rodents the molecular cascades that are activated by stress in the hypothalamus<sup>9,10</sup> and the hippocampus<sup>9,11</sup> during adulthood differ from those that are activated by stress in the infant and change again with aging<sup>7,12</sup>. In addition, sex and genetic factors interact with life events, such as environmental enrichment or isolation, to contribute to the diversity of the stressors and their impacts on an individual's brain.

Taken together, the large array of stress types and contexts, the genetic background, age and sex of the stressed animal, as well as additional factors such as the point in the circadian rhythm at which the stressful event takes place, create a rich and complex matrix of stressors. Each unique stress situation requires an efficient response from numerous neuronal ensembles throughout the CNS, a process that requires astute orchestration. This orchestration occurs through the deployment of a repertoire of signalling

molecules that can bring about the temporal, spatial and context specificity of each individual stress response.

**The diversity of stress mediators**

Each stress mediator has its characteristic, 'classic' spatial and temporal domains. Below we elaborate on the preferred spatial and temporal domains of the three main classes of stress mediators and their individual contribution to the brain's stress response, as a preamble to discussing their coordinated and interactive effects.

**Monoamines.** Shortly after a stressful event, the release of monoamines, including noradrenaline, dopamine and serotonin, is increased in specific neuronal populations<sup>13–16</sup>. This release is triggered by brain circuits that are involved in the evaluation of the stressful event or is triggered indirectly, through activation of the sympathetic nervous system<sup>15</sup>. The extent to which monoaminergic systems are activated depends on many factors, including sex (for example, see REF. 17), the time of day<sup>18</sup> and the controllability or recurrence of the stressor<sup>13</sup>. For instance, activation of raphe neurons (which produce serotonin) by shock exposure is only prominent when the situation is uncontrollable<sup>13,19</sup>.

An enhanced release of monoamines after stress has been demonstrated in the hippocampus, the amygdala, the prefrontal cortex and the nucleus accumbens, but it probably also takes place in many other brain regions. However, the spatial distribution of the consequences of this release depends also on the affinity and distribution of the monoamine receptor subtypes. Thus, the combination of release site and receptor

distribution and affinity provides a single stress mediator with multiple spatial niches and different functions.

Stress-induced monoaminergic release and actions are fast. The release is generally induced within minutes after the onset of the stressor (although region-specific differences exist<sup>20</sup>) and seldom outlasts the duration of stressor exposure. Because monoamines generally act through G protein-coupled receptors, which rapidly transfer their activation to downstream effectors, the rapid rise in their level is quickly translated into altered functioning of neurons that express these receptors.

Each monoamine contributes to specific behavioural aspects of the immediate response to the stressor. For instance, increased levels of noradrenaline supposedly cause a shift from focused processing of sensory information to a more general scanning of the environment, which may provide better solutions for challenging conditions<sup>21</sup>. Dopamine, which is released during moderate stress in the prefrontal cortex<sup>15</sup>, is thought to improve risk assessment and decision strategies, and serotonin is instrumental in reducing post-stress anxiety<sup>22</sup>. Thus, monoamines collectively promote important behavioural strategies that help the animal face and survive the initial phase of a stressful event.

**Neuropeptides.** A number of neuropeptides are released by stress in specific neuronal populations and contribute, often by activating multiple receptors, to the stress response<sup>11,23–26</sup>. Although several of these stress-induced neuropeptides also act on peripheral receptors, we focus here on their release and actions in the brain (TABLE 1).

We confine the discussion to CRH and vasopressin, although other peptides also mediate the effects of stress (orexin, ghrelin and dynorphin) or counteract the stress response under specific contexts (oxytocin and neuropeptide Y); additional peptides may regulate stress-related anxiety and dysphoria (for example, galanin and substance P)<sup>26</sup>.

The canonical stress-activated neuropeptides include the CRH family and vasopressin, which were first discovered in the hypothalamus<sup>24,25</sup>. CRH is released in response to stress from axon terminals in the hypothalamic median eminence and acts on receptors in the pituitary<sup>24</sup>. However, it is now known to also be expressed in neuronal populations in the amygdala<sup>24,26</sup>, the hippocampus<sup>27</sup> and the locus coeruleus<sup>28</sup>. Acting locally, the peptide exerts neuromodulatory effects on target neurons within seconds after its release<sup>9,29,30</sup>, through two G protein-coupled receptors, CRHR1 and CRHR2. CRH receptor occupancy influences neuronal firing patterns<sup>9,29,30</sup>, gene expression<sup>11,26</sup> and behaviour<sup>11,26,31–33</sup>, in a CRH dose- and context-dependent manner. For example, release of CRH in the central nucleus of the amygdala during acute stress enhances memory consolidation<sup>34,35</sup>, and CRH released by modest stress from hippocampal interneurons<sup>11,56</sup> primes long-term potentiation<sup>36</sup> and improves memory<sup>37</sup>. By contrast, hippocampal release of large amounts of CRH in response to severe stress<sup>38,39</sup> can lead to hyperexcitability and seizures<sup>9,40</sup> and to rapid loss of dendritic spines in CA3 pyramidal cells<sup>39</sup>. CRH might also contribute to the structural changes in hippocampal pyramidal cells that are provoked by chronic stress in both adult and developing brains<sup>4,12,38</sup>. Other members of the CRH neuropeptide family, including the urocortins (UCN1, 2 and 3), can bind to CRH receptors and act in distinct spatial domains. Thus, UCN1-expressing neurons in the non-preganglionic Edinger–Westphal nucleus in the brainstem might contribute to stress adaptation<sup>41</sup>.

In the hypothalamus, vasopressin interacts with CRH, promoting adrenocorticotropic hormone (ACTH) release from the pituitary in response to stress<sup>42</sup>. In the brain as a whole, vasopressin acts on a wide array of neurons<sup>25,43</sup> (TABLE 1): in the amygdala, the excitatory actions of vasopressin, perhaps released from dendrites<sup>25</sup>, might contribute to the behavioural stress response. Vasopressin might also modulate emotional memory and anxiety<sup>26</sup>.

The ‘activating’ actions of stress-induced CRH release are mediated primarily through

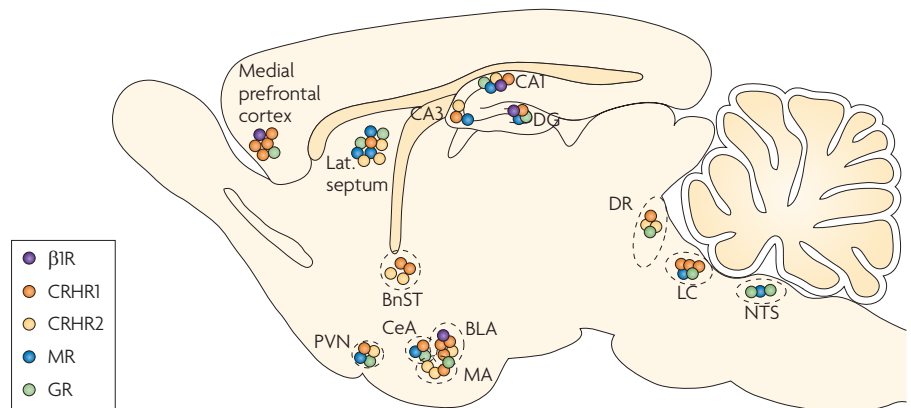

**Figure 2 | ‘Hot spots’ of receptors for key stress mediators.** The  $\beta_1$ -adrenoceptors for noradrenaline ( $\beta_1$ R), CRH receptor 1 (CRHR1), CRHR2 and the mineralocorticoid and glucocorticoid receptors (MRs and GRs, respectively) cluster in ‘hot spots’ in the brain. These hot spots include the prefrontal cortex, specific amygdala nuclei, the hippocampus (CA1, CA3 and the dentate gyrus (DG)), the paraventricular nucleus of the hypothalamus (PVN), the dorsal raphe nuclei (DR) and the locus coeruleus (LC). In these areas, receptors for at least two classes of mediators are highly expressed. The hot spots are strategic hubs that connect networks involved in diverse aspects of the brain’s stress response, including learning and memory, decision making and hormonal, autonomic and emotional responses. BLA, basolateral amygdala; BnST, bed nucleus of the stria terminalis; CeA, central amygdala; CRH, corticotropin-releasing hormone; lat. septum, lateral septum; MA, medial amygdala; NTS, nucleus tractus solitarius. Data from REFS 48,74–78.

binding to CRHR1 (REFS 11,28,33,39), and the panoply of effects described above take place in a time frame of seconds to minutes. In addition, studies in knockout mice suggest that CRHR2 binding could exert effects at longer timescales and might function to shut down the stress response<sup>31,32</sup>. The yin–yang functions of the two CRH receptors described above are remarkably similar to the roles of the two corticosteroid receptors in mediating the early and late effects of stress-induced corticosteroid release on neurons, as described below.

**Steroids.** Corticosteroids are secreted in a pulsatile and circadian fashion; stress triggers the release of a large burst of corticosteroids that is superimposed on these rhythms<sup>44</sup>. Corticosteroids’ access to the brain is regulated by p-glycoproteins<sup>45</sup> (however, see REF. 46), but the circadian pattern and the stress-induced surge of corticosteroid levels are maintained in the brain (as was recently demonstrated for the hippocampus<sup>47</sup>), allowing peripheral and central aspects of the stress response to be integrated. All brain cells, including glia, are in principle exposed to corticosteroid hormones — this contrasts with the spatially restricted pathways through which monoamines and peptides exert their actions. Nevertheless, the sites in the brain where corticosteroids are effective are restricted by the distribution of corticosteroid receptors.

In the mammalian brain, corticosteroid hormones primarily act through mineralocorticoid and glucocorticoid receptors (MRs and GRs, respectively). MRs have a high affinity for corticosteroids, so they are mostly occupied even when circulating corticosteroid levels are low<sup>2</sup>. GRs have tenfold lower affinity; consequently, these receptors are only partially occupied under basal conditions and become more occupied as corticosteroid levels increase — for example, after stress. The two receptor types are differentially distributed in brain<sup>2</sup>. MRs are highly expressed in neurons of the hippocampal formation and the lateral septum and moderately expressed in subnuclei of the amygdala, the hypothalamic paraventricular nucleus (PVN) and the locus coeruleus (FIG. 2). These regions define a circuit that is involved in the cognitive, emotional and neuroendocrine processing of stressful events<sup>5</sup>. The distribution of MRs thus overlaps with the distribution of CRHR1 (REF. 48). GRs are ubiquitously expressed in the brain, but they are enriched in the hippocampus, the lateral septum and the PVN.

On binding of the hormone, corticosteroid receptors translocate to the nucleus, where they act as regulators of gene transcription<sup>49</sup>. Therefore, steroid effects on neuronal function usually require at least an hour to develop and last hours to days. In the hippocampus, MR activation is a prerequisite for maintaining the ongoing information flow<sup>6</sup>, whereas activation of

GRs — for example, after stress — causes a delayed suppression of neuronal excitability and synaptic plasticity<sup>6,50</sup>, thus providing ‘negative-feedback regulation’ of behavioural aspects of the stress response. Moreover, the suppression of synaptic plasticity by GRs — preventing new input (not related to the earlier stressful situation) being encoded — could serve to protect the stress-related information that is being consolidated after stress exposure. The slow,

gene-mediated consequences of GR activation depend on the life history; for example, adverse early-life experiences or chronic stress in adulthood influence the number and the functioning of GRs in the hippocampus<sup>6,51</sup>. Preliminary evidence suggests that in the basolateral amygdala — unlike in the hippocampus — GR activation has lasting excitatory rather than suppressive and normalizing effects on cell firing<sup>52</sup>. This illustrates the fact that one mediator acting through one receptor type can have multiple effects, depending on the life history and cellular context.

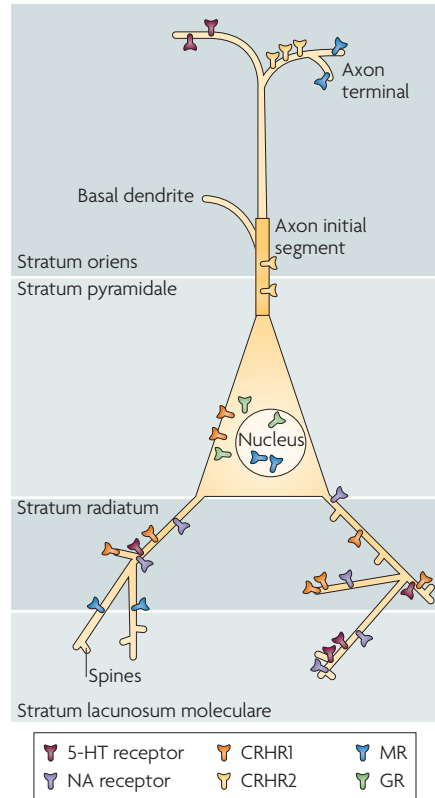

**Figure 3 | Subcellular localization of stress-mediator receptors.** The actions of different stress mediators on a single neuron are orchestrated through the distinct subcellular localization of the relevant receptors. This is illustrated in this cartoon of a hypothetical pyramidal cell (which includes features that exist on either or both CA3 and CA1 principal cells). For example, corticotropin-releasing hormone receptor 1 (CRHR1) is located in somata as well as on dendrites and dendritic spines<sup>3,39,48,56</sup>, whereas CRHR2 reside on the axon initial segment (Y. Chen, personal communication). In addition, monoamine receptors that terminate on hippocampal pyramidal cells reside on specific dendritic domains<sup>57,58</sup>. Note that the subcellular distribution patterns of each receptor might differ between brain areas. For instance, glucocorticoid receptors (GRs) might be present on postsynaptic (dendritic) domains in certain amygdala neurons<sup>59</sup>. 5-HT, 5-hydroxytryptamine; MR, mineralocorticoid receptors; NA, noradrenaline.

**Acting in concert**

As described above, each of the stress mediators has its own preferred spatial and temporal domains of release and action. In principle, this allows the brain to deal with the entire range of stress-provoked challenges — from immediate attention and strategy decisions that are important for survival in the short term, to storage of information about the stressful situation in case similar events are encountered in the future, which is advantageous in the long term. However, the actions of the different stress mediators need to be orchestrated into a coordinated stress response. This is enabled by overlap in the spatial and temporal niches of action of the different mediators, which allows their actions to converge. In addition, there is increasing evidence of direct interactions between the individual stress mediators.

**Spatial niches.** The fact that stress mediators are released only in certain areas and act only on those neurons that express specific receptor subtypes was discussed above. Interestingly, different stress mediator receptors are often expressed in ‘hot spots’ of the brain, such as the prefrontal cortex, the amygdala, the hippocampus and the neurotransmitter synthesis areas (for example, the dorsal raphe nucleus and the locus coeruleus) (FIG. 2), consistent with the concept of spatial convergence of their actions<sup>53</sup>. The hot spots are strategic hubs that connect networks involved in different aspects of the stress response. For example, neurons in the basolateral amygdala, which are affected by noradrenaline, dopamine, CRH and corticosteroids, are instrumental for sympathetic and neuroendocrine activation (through their output to the central amygdala), for fine-tuning of arousal (through reciprocal connections with the locus coeruleus) and for the processing of emotional and contextual aspects of stress (through

the prefrontal cortex and hippocampus). A second hot spot is the hippocampus, where individual neurons can express receptors for corticosteroids, neuropeptides, monoamines (including serotonin and noradrenaline) and opioids (FIG. 3), enabling the fine-tuning of neuronal firing in response to a range of signals. Thus, although each stress mediator has a characteristic and unique spatial domain, their functional contribution to the stress response is subject to integration with that of other mediators, through convergence on interconnected networks (FIG. 2).

Here we carry this concept further, by proposing that both the spatial specificity and the integration of the effects of distinct neuromodulators apply even at the level of a single neuron: receptors that bind a given mediator are not only localized to specific neuronal populations but also reside in selective subcellular neuronal domains, providing exquisite spatial resolution to a mediator’s effects. In other words, the site of release coupled with receptor localization provides a fine-resolution spatial specificity regarding the actions of stress mediators. This is illustrated in the hypothetical hippocampal pyramidal neuron shown in FIG. 3. In this neuron, cytoplasmic receptors for corticosteroids — the MRs and GRs that, on binding, translocate to the nucleus — are localized in the soma<sup>54</sup>, whereas the so-called membrane MRs are found in both the pre- and the postsynaptic membrane<sup>55</sup>. Similarly, CRHR1 is located in somata, on dendrites<sup>38,39</sup> and even in the postsynaptic density of dendritic spines<sup>56</sup>, whereas CRHR2 seems to reside on the axon initial segment (Y. Chen, personal communication). In addition, monoamine receptors in hippocampal pyramidal cells reside on specific dendritic domains<sup>57,58</sup>. It should be noted that the subcellular distribution of receptors is brain region-specific. For example, dendritically located GRs have been found in the lateral amygdala<sup>59</sup>, and presynaptically located CRHR1 has been found in locus coeruleus neurons<sup>28,60</sup>. This exquisite spatial control of receptor localization ensures that the net sum of the effects of stress on the activity of a single neuron will be a composite of the local effects of the different stress mediators.

**Temporal niches.** Stress responses take place at timescales that span milliseconds to days. As discussed, the different modulators have classically been considered to act at distinctive temporal profiles, allowing both activation and termination of the stress response. In general, stress is assumed to cause an



initial, acute wave of effects that is carried by monoamines and peptides, starting within seconds after the onset of a stressor<sup>61</sup>. A second wave of ‘molecular’ effects of stress is typically discernible starting one to two hours after stress exposure. These molecular effects are mediated primarily by GRs (acting as transcription factors) and CRHR2 signalling and inhibit the lingering effects of the first wave of stress-induced actions. This restores allostasis (that is, homeostatic control with a varying setpoint (governed by demand), which is thought to achieve stability through change<sup>4</sup>) for both cognitive and neuroendocrine functions.

Importantly, recent evidence concerning the full range of actions of the diverse stress mediators has demonstrated that the mediators exert more subtle and context-specific actions outside their classical temporal niches, and that these can be better considered within the framework of three temporal (and functional) domains (BOX 1). For example, monoamines can induce synaptic responses within seconds of stressor onset but also, through a different signalling cascade, activate immediate early genes such as *ARC*; this extends their actions (for example, on memory formation) to a more delayed time domain<sup>62</sup>. The consequences of such a delayed pathway for stress responsiveness are particularly significant when the downstream targets include genes that encode catecholamine-synthesizing enzymes<sup>63</sup>, as this would amplify the original response. In another example, activation of CRHR1 can within seconds alter neuronal afterhyperpolarization<sup>29</sup> and phosphorylate the transcription factor CRE-binding protein (CREB)<sup>11</sup>. The downstream effects of CREB phosphorylation — that is, transcriptional regulation of CRE (cAMP-responsive element)-containing genes, including *c-FOS* and *CRH* — take place over hours. Depending on which genes’ transcription is affected by CREB, this contributes to the activation and/or resolution of the stress response.

Conversely, corticosteroids (which are classically thought to be slow-acting) also rapidly change brain functioning through non-genomic pathways — for example, in the hypothalamus<sup>64</sup> and hippocampus<sup>65</sup>. In CA1 neurons, such rapid effects seem to be mediated by the binding of corticosterone to MRs in the pre- and postsynaptic plasma membrane<sup>55</sup>. The rapid MR activation facilitates increases in neuronal excitability by increasing the probability of glutamate release<sup>65</sup>, the trafficking of glutamate receptor subunits<sup>66</sup> and the suppression of a K<sup>+</sup> conductance<sup>55</sup>. Interestingly, the apparent

**Box 1 | Temporal profiles of the orchestrated stress response**

The stress response has classically been characterized by two temporal ‘waves’ of stress mediator actions. The first includes rapid actions of noradrenaline, serotonin, dopamine and corticotropin-releasing hormone (CRH) (the latter being predominantly mediated by CRH receptor 1). These rapid actions of stress mediators promote vigilance, alertness, appraisal of the situation and the choice of an optimal strategy to face the challenge. Because local increases in stress mediator levels are short-lived, and because their actions typically quickly subside, this first wave of events is not optimal for provoking the sustained, adaptive components of a stress response, such as the consolidation of information associated with (that is, the memory of) the stressor. This is instead accomplished through alterations of gene expression and cell function, classically considered the second wave and attributed to corticosteroids acting through glucocorticoid receptors.

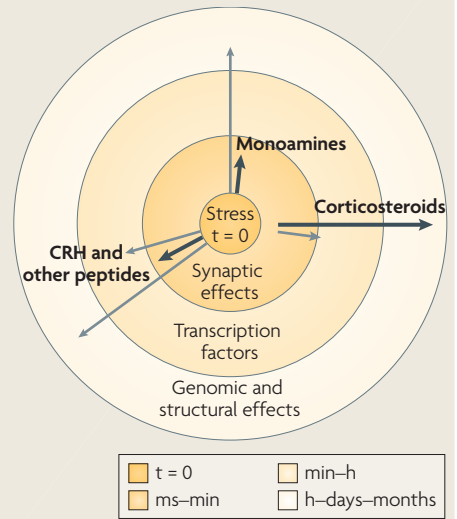

Recent work suggests that the temporal profile of the orchestrated stress response might fit better into a framework of three temporal domains that denote distinct mechanisms of operation of the stress mediators. For example, receptor activation by monoamines and peptides can, in addition to having rapid synaptic effects, regulate transcription factors (such as CRE-binding protein and AP1) within a seconds-to-minutes time frame<sup>3,11,63</sup>. This rapid activation (or deactivation) of transcription factors can lead to sustained genomic changes that help the organism to respond to stressors of different magnitudes and durations, as well as to recurrent stress. Conversely, corticosterone, through non-genomic pathways involving membrane-located mineralocorticoid receptors<sup>65</sup>, can act within minutes<sup>55</sup>. Taken together, these findings blur the classical distinction between rapid and delayed responses to stress.

In view of the above, the temporal action profiles of stress mediators might best be considered as a series of vectors commencing at the onset of stress, as shown in the figure. Each hormone has a preferred temporal vector (shown as black arrows) that is associated with a specific mode of cellular function (for example, synaptic or transcriptional). In addition, most modulators exert stress-related actions through alternative molecular and cellular pathways (shown as grey arrows), which take place in different temporal niches. The length of each vector in the figure corresponds to the temporal domain denoted by the concentric circles. Note that the non-genomic effects of corticosteroids develop slightly later than the rapid aminergic and peptidergic actions, because it takes time to transport the hormones from the adrenals (where they are secreted) to the brain. The combined actions of each stress mediator make up its compound temporal and functional profile.

affinity of this membrane MR for corticosterone is a tenth that of the nuclear MR<sup>65</sup>. This low-affinity MR supposedly enables the hippocampus to sense pulsatile corticosteroid fluctuations and, importantly, the surge in corticosterone levels that occurs during the initial response to stress<sup>67</sup>. The rapid actions of membrane MRs thus join those of other stress mediators like CRH and noradrenaline.

In summary, although each stress modulator contributes to the orchestrated stress response through a main role with a defined temporal niche, it is now clear that most modulators play additional, minor parts (BOX 1). These effects, which transcend the classical temporal niches, enable further gradation and integration of responses to stressors of diverse nature, magnitude and duration.

**Direct interactions.** Recently, several interactions between two or more stress mediators (and between stress mediators and other neurotransmitters) have emerged, showing that the total contribution of stress mediators to the stress response is more than just the sum of their individual effects (FIG. 4). For instance, the activity of noradrenergic neurons in the LC is modulated by interactions between CRH, a stress mediator, and opioids and glutamate so as to achieve optimal behavioural adaptation to a stressor<sup>28</sup>. Thus, as a result of stress exposure, LC noradrenergic cell firing shifts from a moderate, tonic activity that is permissive of a superimposed phasic activity to a high tonic firing that prevents phasic firing. A high ratio of phasic to tonic firing is optimal for responding to sensory stimuli and is associated with

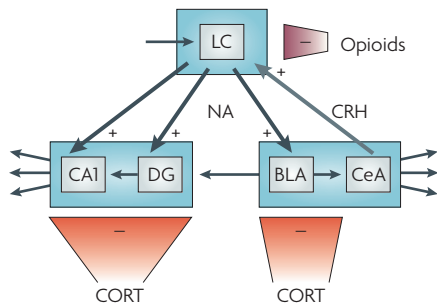

**Figure 4 | Direct interaction between different stress mediators.** Noradrenaline (NA), corticotropin-releasing hormone (CRH), opioids and corticosterone (CORT) interact in the locus coeruleus (LC) and its projection areas (including the hippocampus and the amygdala) to orchestrate exquisite tuning of neuronal firing patterns in response to stress. Exposure to stress shifts LC noradrenergic cell firing — which is normally kept at a moderate level by glutamatergic input, here represented by the top left arrow — from a moderate tonic activity to high tonic firing that prevents phasic firing. This shift is mediated by CRH projections from the central amygdala on to CRH 1 receptors in the LC<sup>28</sup>. In turn, LC noradrenergic cells project to the basolateral amygdala (BLA), hippocampal CA1 and the dentate gyrus (DG). Here noradrenaline, released shortly after stress exposure, enhances excitability, promoting the encoding of stress-related information. Glutamatergic output from the BLA to the DG is thought to provide a means to ‘emotionally tag’ information processed in the hippocampus, thus rendering it preference in storage<sup>71</sup>. The stress-induced enhancement in activity in the LC, the BLA, the DG and CA1 (which in the DG is aided by rapid corticosteroid actions; see main text) is gradually reversed, resulting in a return to the pre-stress activity level. In the LC, the level of tonic firing is reduced by opiates that bind to  $\kappa$ - and  $\mu$ -opioid receptors<sup>68</sup>. In the BLA, the DG and CA1, these gradual normalizing effects are exerted by corticosterone, presumably through glucocorticoid receptor-mediated gene-dependent cascades<sup>6,70,79</sup>. The + signs indicate that the stress mediator enhances cell firing, whereas the - signs indicate decreased cell activity. CeA, central amygdala.

focused attention and maintenance of ongoing behaviour. By contrast, a low ratio, which results from stress exposure, is thought to promote arousal, scanning of the environment and decision making, thus increasing the chance of finding the optimal way to cope with the stressor<sup>21</sup>. Whereas glutamate is instrumental in enhancing the phasic firing, the stress-induced shift towards high tonic firing patterns is mediated by CRH projections from the central amygdala and by activation of CRHR1 in the rostralateral dendritic zone of the LC<sup>28</sup>. In turn, opiates inhibit LC tonic firing by binding to  $\kappa$ - and

$\mu$ -opioid receptors<sup>68</sup>. Thus, endogenous opioid release might be important for resetting the level and mode of LC noradrenergic neuron activity after stress, helping to terminate the central noradrenergic response to the stressor<sup>69</sup>.

In the projection areas of the LC, direct interactions between stress mediators also fine-tune the activation and termination of noradrenergic signalling. Thus, in the hippocampal dentate gyrus noradrenaline enhances excitability and synaptic plasticity, and this effect can be augmented by rapidly acting corticosterone<sup>70</sup>. Behavioural observations in combination with local pharmacological interventions have led to the conclusion that there is also synergy between noradrenaline and glucocorticoids in the rodent basolateral amygdala<sup>71</sup>. This synergy is thought to promote consolidation of emotional information<sup>72</sup>. However, when corticosterone acts through the genomic pathway it can also suppress noradrenergic activity. In this slow temporal domain, the steroid effectively suppresses the facilitation of information transfer by noradrenaline<sup>6,70</sup>. This suppression of activity is supported by other slowly developing corticosteroid-monoamine interactions, including the steroid-induced enhancement of hyperpolarizing effects that are mediated by the serotonin 1A receptor<sup>6</sup>.

There are additional examples of interactions between monoamines and the neuropeptide CRH<sup>34,73</sup>. In the basolateral amygdala, CRH might interact with  $\beta$ -adrenergic activation accomplished by endogenous monoamines<sup>34</sup>. Such interactions also take place in amygdala projection areas. For instance, glutamate transmission in the pathway from the basolateral amygdala to the medial prefrontal cortex — which is important for emotional processing and decision making — is depressed by dopamine activation of D1 or D5 receptors, and CRH (which on its own does not affect glutamate transmission) augments this depression<sup>73</sup>. Importantly, this interaction is context dependent; for example, chronic cocaine administration switches the synergistic actions of dopamine and CRH from suppressing to facilitating glutamate transmission.

Note that interactions between stress mediators can take place in a single temporal domain (for example, the interaction between CRH and glutamate) or between the classic temporal niches: CRH ‘primes’ hippocampal neurons for subsequent excitatory neurotransmission<sup>36</sup>, and fast-acting monoamines might prime neurons for

subsequent effects of stress-induced, slower-acting mediators. The mechanisms by which these interactions take place require further study.

These examples illustrate that the spatial convergence and temporal overlap of the various stress mediators enable multiple, direct and rapid interactions, resulting in synergistic actions that orchestrate the acute stress response. Longer-lasting or delayed interactions between stress mediators might promote the termination of the stress response.

### Conclusions and future directions

The ability to change neuronal activity (and hence behaviour and cognition) both rapidly and enduringly in response to threatening challenges is crucial for survival and has thus resulted in a highly coordinated, complex and evolutionarily conserved stress-response system. Because different challenges require distinct responses (for example, social decisions or flight) that involve different sets of neuronal populations acting in concert or sequentially, the brain has evolved a system that can produce such diverse alterations in neuronal activity. This system consists of the stress mediators described in this Perspective, which not only occupy characteristic niches of time, space and function, but also are exquisitely coordinated at multiple levels to create an orchestrated stress-response symphony. This ‘stress neuro-symphony’ provides the capacity to generate precise, focused alterations in neuronal activity in response to stress signals. These alterations can range spatially from individual synapses up to the whole animal and temporally from milliseconds to days.

Although our understanding of the individual instruments of this stress neuro-symphony has increased substantially, more studies are needed to examine the additional actions of and interactions between the stress mediators. New tools allow us to interfere with selected aspects of a stress mediator’s signalling pathway in a site-specific and inducible manner, and therefore let us examine the mediator’s relevance to cellular activity in freely moving animals. Genome-wide screening tools will enable better study of the full spectrum of each individual mediator’s actions, and of the coordinated effects of these mediators on stress-related programmes of gene expression, which in turn influence behaviour in the long term. Ultimately, the roles that interactions between stress mediators have in orchestrating human cognitive performance will need to be investigated.

Finally, in view of the complexity of this stress neuro-symphony, it is not surprising that many of its components can be deranged, leading to stress-related disorders including depression and anxiety. An improved understanding of how this system functions will enable better use of current therapeutic interventions and the development of new clinically useful drugs.

Marian Joëls is at SILS-CNS, University of Amsterdam, Kruislaan 320, 1098 SM Amsterdam, the Netherlands.

Tallie Z. Baram is at the University of California, Irvine, Departments of Pediatrics and Anatomy & Neurobiology, Medical Sciences I, ZOT 4475, Irvine, California 92697-4475, USA.

e-mails: [M.Joels@uva.nl](mailto:M.Joels@uva.nl); [tallie@uci.edu](mailto:tallie@uci.edu)

doi:10.1038/nrn2632

Published online 2 April 2009

1. Ulrich-Lai, Y. M. & Herman, J. P. *et al.* Neural regulation of endocrine and autonomic stress responses. *Nature Rev. Neurosci.* (in the press).
2. De Kloet, E. R., Joëls, M. & Holsboer, F. Stress and the brain: from adaptation to disease. *Nature Rev. Neurosci.* **6**, 463–475 (2005).
3. Fenoglio, K. A., Brunson, K. L. & Baram, T. Z. Hippocampal neuroplasticity induced by early-life stress: functional and molecular aspects. *Front. Neuroendocrinol.* **27**, 180–192 (2006).
4. McEwen, B. S. Physiology and neurobiology of stress and adaptation: central role of the brain. *Physiol. Rev.* **87**, 873–904 (2007).
5. McGaugh, J. L. The amygdala modulates the consolidation of memories of emotionally arousing experiences. *Annu. Rev. Neurosci.* **27**, 1–28 (2004).
6. Joëls, M., Karst, H., Krugers, H. J. & Lucassen, P. J. Chronic stress: implications for neuronal morphology, function and neurogenesis. *Front. Neuroendocrinol.* **28**, 72–96 (2007).
7. Lupien, S. J. *et al.* Stress hormones and human memory function across the lifespan. *Psychoneuroendocrinology* **30**, 225–242 (2005).
8. Shors, T. J. Stressful experience and learning across the lifespan. *Annu. Rev. Psychol.* **57**, 55–85 (2006).
9. Baram, T. Z. & Hatalski, C. G. Neuroepitide-mediated excitability: a key triggering mechanism for seizure generation in the developing brain. *Trends Neurosci.* **21**, 471–476 (1998).
10. Rice, C. J., Sandman, C. A., Lenjavi, M. R. & Baram, T. Z. A novel mouse model for acute and long-lasting consequences of early life stress. *Endocrinology* **149**, 4892–4900 (2008).
11. Chen, Y., Fenoglio, K. A., Dube, C. M., Grigoriadis, D. E. & Baram, T. Z. Cellular and molecular mechanisms of hippocampal activation by acute stress are age-dependent. *Mol. Psychiatry* **11**, 992–1002 (2006).
12. Brunson, K. L. *et al.* Mechanisms of late-onset cognitive decline after early-life stress. *J. Neurosci.* **25**, 9328–9338 (2005).
13. Maier, S. F. & Watkins, L. R. Stressor controllability and learned helplessness: the roles of the dorsal raphe nucleus, serotonin, and corticotropin-releasing factor. *Neurosci. Biobehav. Rev.* **29**, 829–841 (2005).
14. Morilak, D. A. *et al.* Role of brain norepinephrine in the behavioral response to stress. *Prog. Neuropsychopharmacol. Biol. Psychiatry* **29**, 1214–1224 (2005).
15. Goto, Y., Otani, S. & Grace, A. A. The yin and yang of dopamine release: a new perspective. *Neuropharmacology* **53**, 583–587 (2007).
16. Linthorst, A. C. & Reul, J. M. Stress and the brain: solving the puzzle using microdialysis. *Pharmacol. Biochem. Behav.* **90**, 163–173 (2008).
17. Mitsushima, D., Yamada, K., Takase, K., Funabashi, T. & Kimura, F. Sex differences in the basolateral amygdala: the extracellular levels of serotonin and dopamine, and their responses to restraint stress in rats. *Eur. J. Neurosci.* **24**, 3245–3254 (2006).
18. Piazza, P. V. *et al.* Glucocorticoids have state-dependent stimulant effects on the mesencephalic dopaminergic transmission. *Proc. Natl Acad. Sci. USA* **93**, 8716–8720 (1996).
19. Amat, J. *et al.* Medial prefrontal cortex determines how stressor controllability affects behavior and dorsal raphe nucleus. *Nature Neurosci.* **8**, 365–371 (2005).
20. Jackson, M. E. & Moghaddam, B. Stimulus-specific plasticity of prefrontal cortex dopamine neurotransmission. *J. Neurochem.* **88**, 1327–1334 (2004).
21. Aston-Jones, G. & Cohen, J. D. An integrative theory of locus coeruleus-norepinephrine function: adaptive gain and optimal performance. *Annu. Rev. Neurosci.* **28**, 403–450 (2005).
22. Adamec, R., Holmes, A. & Blundell, J. Vulnerability to lasting anxiogenic effects of brief exposure to predator stimuli: sex, serotonin and other factors-relevance to PTSD. *Neurosci. Biobehav. Rev.* **32**, 1287–1292 (2008).
23. Mathew, S. J., Price, R. B. & Charney, D. S. Recent advances in the neurobiology of anxiety disorders: implications for novel therapeutics. *Am. J. Med. Genet. C Semin. Med. Genet.* **148**, 89–98 (2008).
24. Swanson, L. W., Sawchenko, P. E., Rivier, J. & Vale, W. W. Organization of ovine corticotropin-releasing factor immunoreactive cells and fibers in the rat brain: an immunohistochemical study. *Neuroendocrinology* **36**, 165–186 (1983).
25. Landgraf, R. & Neumann, I. D. Vasopressin and oxytocin release within the brain: a dynamic concept of multiple and variable modes of neuropeptide communication. *Front. Neuroendocrinol.* **25**, 150–176 (2004).
26. Koob, G. F. A role for brain stress systems in addiction. *Neuron* **59**, 11–34 (2008).
27. Chen, Y., Bender, R. A., Frotscher, M. & Baram, T. Z. Novel and transient populations of corticotropin-releasing hormone-expressing neurons in developing hippocampus suggest unique functional roles: a quantitative spatiotemporal analysis. *J. Neurosci.* **21**, 7171–7181 (2001).
28. Valentino, R. J. & Van Bockstaele, E. Convergent regulation of locus coeruleus activity as an adaptive response to stress. *Eur. J. Pharmacol.* **583**, 194–203 (2008).
29. Aldenhoff, J. B., Gruol, D. L., Rivier, J., Vale, W. & Siggins, G. R. Corticotropin releasing factor decreases postburst hyperpolarizations and excites hippocampal neurons. *Science* **221**, 875–877 (1983).
30. Gallagher, J. P., Orozco-Cabal, L. F., Liu, J. & Shinnick-Gallagher, P. Synaptic physiology of central CRH system. *Eur. J. Pharmacol.* **583**, 215–225 (2008).
31. Coste, S. C. *et al.* Abnormal adaptations to stress and impaired cardiovascular function in mice lacking corticotropin-releasing hormone receptor-2. *Nature Genet.* **24**, 403–409 (2000).
32. Bale, T. L. *et al.* Mice deficient for corticotropin-releasing hormone receptor-2 display anxiety-like behaviour and are hypersensitive to stress. *Nature Genet.* **24**, 410–414 (2000).
33. Muller, M. B. *et al.* Limbic corticotropin-releasing hormone receptor 1 mediates anxiety-related behavior and hormonal adaptation to stress. *Nature Neurosci.* **6**, 1100–1107 (2003).
34. Roozendaal, B., Brunson, K. L., Holloway, B. L., McGaugh, J. L. & Baram, T. Z. Involvement of stress-released corticotropin-releasing hormone in the basolateral amygdala in regulating memory consolidation. *Proc. Natl Acad. Sci. USA* **99**, 13908–13913 (2002).
35. Merali, Z., Khan, S., Michaud, D. S., Shippey, S. A. & Anisman, H. Does amygdaloid corticotropin-releasing hormone (CRH) mediate anxiety-like behaviors? Dissociation of anxiogenic effects and CRH release. *Eur. J. Neurosci.* **20**, 229–239 (2004).
36. Blank, T., Nijholt, I., Eckart, K. & Spiess, J. Priming of long-term potentiation in mouse hippocampus by corticotropin-releasing factor and acute stress: implications for hippocampus-dependent learning. *J. Neurosci.* **22**, 3788–3794 (2002).
37. Wang, H. L., Wayner, M. J., Chai, C. Y. & Lee, E. H. Corticotropin-releasing factor produces a long-lasting enhancement of synaptic efficacy in the hippocampus. *Eur. J. Neurosci.* **10**, 3428–3437 (1998).
38. Chen, Y. *et al.* Modulation of dendritic differentiation by corticotropin-releasing factor in the developing hippocampus. *Proc. Natl Acad. Sci. USA* **101**, 15782–15787 (2004).
39. Chen, Y., Dube, C. M., Rice, C. J. & Baram, T. Z. Rapid loss of dendritic spines after stress involves derangement of spine dynamics by corticotropin-releasing hormone. *J. Neurosci.* **28**, 2903–2911 (2008).
40. Ehlers, C. L. *et al.* Corticotropin releasing factor produces increases in brain excitability and convulsive seizures in rats. *Brain Res.* **278**, 332–336 (1983).
41. Kozicz, T. On the role of urocortin 1 in the non-preganglionic Edinger-Westphal nucleus in stress adaptation. *Gen. Comp. Endocrinol.* **153**, 235–240 (2007).
42. Harbuz, M. S. *et al.* Paradoxical responses of hypothalamic corticotropin-releasing factor (CRF) messenger ribonucleic acid (mRNA) and CRF-41 peptide and adenylylphosphoprotein mRNA during chronic inflammatory stress. *Endocrinology* **130**, 1394–1400 (1992).
43. Ragenbass, M. Overview of cellular electrophysiological actions of vasopressin. *Eur. J. Pharmacol.* **583**, 243–254 (2008).
44. Young, E. A., Abelson, J. & Lightman, S. L. Cortisol pulsatility and its role in stress regulation and health. *Front. Neuroendocrinol.* **25**, 69–76 (2004).
45. Karszen, A. M. *et al.* Multidrug resistance P-glycoprotein hampers the access of cortisol but not of corticosterone to mouse and human brain. *Endocrinology* **142**, 2686–2694 (2001).
46. Mason, B. L., Pariante, C. M. & Thomas, S. A. A revised role for p-glycoprotein in the brain distribution of dexamethasone, cortisol, and corticosterone in wild type and ABCB1A/B-deficient mice. *Endocrinology* **149**, 5244–5253 (2008).
47. Droste, S. K. *et al.* Corticosterone levels in the brain show a distinct ultradian rhythm but a delayed response to forced swim stress. *Endocrinology* **149**, 3244–3253 (2008).
48. Chen, Y., Brunson, K. L., Muller, M. B., Cariaga, W. & Baram, T. Z. Immunocytochemical distribution of corticotropin-releasing hormone receptor type-1 (CRF<sub>1</sub>)-like immunoreactivity in the mouse brain: light microscopy analysis using an antibody directed against the C-terminus. *J. Comp. Neurol.* **420**, 305–323 (2000).
49. Lu, N. Z. *et al.* International Union of Pharmacology. LXV. The pharmacology and classification of the nuclear receptor superfamily: glucocorticoid, mineralocorticoid, progesterone, and androgen receptors. *J. Pharmacol. Rev.* **58**, 782–797 (2006).
50. Kim, J. J. & Diamond, D. M. The stressed hippocampus, synaptic plasticity and lost memories. *Nature Rev. Neurosci.* **3**, 453–462 (2002).
51. Champagne, D. L. *et al.* Maternal care and hippocampal plasticity: evidence for experience-dependent structural plasticity, altered synaptic functioning, and differential responsiveness to glucocorticoids and stress. *J. Neurosci.* **28**, 6037–6045 (2008).
52. Duvarci, S. & Paré, D. Glucocorticoids enhance the excitability of principal basolateral amygdala neurons. *J. Neurosci.* **27**, 4482–4491 (2007).
53. Bloom, F. E. The functional significance of neurotransmitter diversity. *Am. J. Physiol.* **246**, C184–C194 (1984).
54. Nishi, M., Ogawa, H., Ito, T., Matsuda, K. I. & Kawata, M. Dynamic changes in subcellular localization of mineralocorticoid receptor in living cells: in comparison with glucocorticoid receptor using dual-color labeling with green fluorescent protein spectral variants. *Mol. Endocrinol.* **15**, 1077–1092 (2001).
55. Olijslagers, J. E. *et al.* Rapid changes in hippocampal CA1 pyramidal cell function via pre- as well as postsynaptic membrane mineralocorticoid receptors. *Eur. J. Neurosci.* **27**, 2542–2550 (2008).
56. Chen, Y. *et al.* Hippocampal corticotropin releasing hormone: pre- and postsynaptic location and release by stress. *Neuroscience* **126**, 533–540 (2004).
57. Swanson, L. W., Kohler, C. & Björklund, A. in *Handbook of Chemical Neuroanatomy* vol. 5 (eds Björklund, A., Hökfelt, T. & Swanson, L. W.) 125–227 (Elsevier, Amsterdam, 1987).
58. Oleskevich, S., Descarries, L. & Lacaille, J. C. Quantified distribution of the noradrenaline innervation in the hippocampus of adult rat. *J. Neurosci.* **9**, 3803–3815 (1989).
59. Johnson, L. R., Farb, C., Morrison, J. H., McEwen, B. S. & LeDoux, J. E. Localization of glucocorticoid receptors at postsynaptic membranes in the lateral amygdala. *Neuroscience* **136**, 289–299 (2005).
60. Reyes, B. A., Valentino, R. J. & Van Bockstaele, E. J. Stress-induced intracellular trafficking of corticotropin-releasing factor receptors in rat locus coeruleus neurons. *Endocrinology* **149**, 122–130 (2008).
61. Joëls, M., Pu, Z., Wiegert, O. & Krugers, H. J. Learning under stress: how does it work? *Trends Cogn. Sci.* **10**, 152–158 (2006).



62. McIntyre, C. K. *et al.* Memory-influencing intra-basolateral amygdala drug infusions modulate expression of Arc protein in the hippocampus. *Proc. Natl Acad. Sci. USA* **102**, 10718–10723 (2005).
63. Sabban, E. L. & Kvetnansky, R. Stress-triggered activation of gene expression in catecholaminergic systems: dynamics of transcriptional events. *Trends Neurosci.* **24**, 91–98 (2001).
64. Tasker, J. G., Di, S. & Malcher-Lopes, R. Minireview: rapid glucocorticoid signaling via membrane-associated receptors. *Endocrinology* **147**, 5549–5556 (2006).
65. Karst, H. *et al.* Mineralocorticoid receptors are indispensable for nongenomic modulation of hippocampal glutamate transmission by corticosterone. *Proc. Natl Acad. Sci. USA* **102**, 19204–19207 (2005).
66. Groc, L., Choquet, D. & Chaouloff, F. The stress hormone corticosterone conditions AMPAR surface trafficking and synaptic potentiation. *Nature Neurosci.* **11**, 868–870 (2008).
67. Joëls, M., Karst, H., DeRijk, R. & de Kloet, E. R. The coming out of the brain mineralocorticoid receptor. *Trends Neurosci.* **31**, 1–7 (2008).
68. Kreibich, A. *et al.* Presynaptic inhibition of diverse afferents to the locus ceruleus by  $\kappa$ -opioid receptors: a novel mechanism for regulating the central norepinephrine system. *J. Neurosci.* **28**, 6516–6525 (2008).
69. Curtis, A. L., Bello, N. T. & Valentino, R. J. Evidence for functional release of endogenous opioids in the locus ceruleus during stress termination. *J. Neurosci.* **21**, RC152 (2001).
70. Pu, Z., Krugers, H. J. & Joëls, M. Corticosterone time-dependently modulates beta-adrenergic effects on long-term potentiation in the hippocampal dentate gyrus. *Learn. Mem.* **14**, 359–367 (2007).
71. Akirav, I. & Richter-Levin, G. Mechanisms of amygdala modulation of hippocampal plasticity. *J. Neurosci.* **22**, 9912–9921 (2002).
72. Roozendaal, B., Okuda, S., de Quervain, D. J. & McGaugh, J. L. Glucocorticoids interact with emotion-induced noradrenergic activation in influencing different memory functions. *Neuroscience* **138**, 901–910 (2006).
73. Orozco-Cabal, L. *et al.* Dopamine and corticotropin-releasing factor synergistically alter basolateral amygdala-to-medial prefrontal cortex synaptic transmission: functional switch after chronic cocaine administration. *J. Neurosci.* **28**, 529–542 (2008).
74. Chalmers, D. T., Lovenberg, T. W. & De Souza, E. B. Localization of novel corticotropin-releasing factor receptor (CRF2) mRNA expression to specific subcortical nuclei in rat brain: comparison with CRF1 receptor mRNA expression. *J. Neurosci.* **15**, 6340–6350 (1995).
75. Rainbow, T. C., Parsons, B. & Wolfe, B. B. Quantitative autoradiography of  $\beta$ 1- and  $\beta$ 2-adrenergic receptors in rat brain. *Proc. Natl Acad. Sci. USA* **81**, 1585–1589 (1984).
76. Reul, J. M. H. M. & de Kloet, E. R. Anatomical resolution of two types of corticosterone receptor sites in rat brain with *in vitro* autoradiography and computerized image analysis. *J. Steroid Biochem.* **24**, 269–272 (1986).
77. Härfstrand, A. *et al.* Glucocorticoid receptor immunoreactivity in monoaminergic neurons of rat brain. *Proc. Natl Acad. Sci. USA* **83**, 9779–9783 (1986).
78. Van Pett, K. *et al.* Distribution of mRNAs encoding CRF receptors in brain and pituitary of rat and mouse. *J. Comp. Neurol.* **428**, 191–212 (2000).
79. Pu, Z., Krugers, H. J. & Joëls, M. Beta-adrenergic facilitation of synaptic plasticity in the rat basolateral amygdala *in vitro* is gradually reversed by corticosterone. *Learn. Mem.* **16**, 155–160 (2009).
80. Avishai-Eliner, S., Brunson, K. L., Sandman, C. A. & Baram, T. Z. Stressed-out, or in (utero)? *Trends Neurosci.* **25**, 518–524 (2002).
81. Lim, M. M. *et al.* CRF receptors in the nucleus accumbens modulate partner preference in prairie voles. *Horm. Behav.* **51**, 508–515 (2007).
82. Chavkin, C. Dynorphins are endogenous opioid peptides released from granule cells to act neurohumorally and inhibit excitatory neurotransmission in the hippocampus. *Prog. Brain Res.* **125**, 363–367 (2000).

#### Acknowledgements

The authors thank E. R. de Kloet and A. Korosi for critical reading of the text and help with the figures. Supported by NWO grant #91204042 (M.J.) and grants NS29012 and MH 73136 from the National Institute of Health (T.Z.B.).

#### Competing financial interests

The authors declare no competing financial interests.